



TL100

COMPACT WHEELED LOADER



WORKS FOR YOU.™

THE EFFICIENT ALL-ROUNDER

Just when you need it...

The Terex® TL100 wheel loader is economical and versatile enough to cope with a wide variety of applications. With its new engine technology and state-of-the-art operating concept, the compact wheeled loader is sure to be a hit on any construction site. It is productive, efficient and reliable. This workhorse never knows when to stop: from gardening and agriculture to structural/civil engineering and municipal use.

Made in Germany

Terex Compact Germany has developed and manufactured compact construction machinery for over 75 years, including more than 30 years at the current Crailsheim site.



Technical data *

Operating weight	5800 kg
Engine power	55.4 kW (75 hp)
Bucket capacity	1.0-1.55 m ³
Steering	Articulated steering

* Subject to modification

IT REALLY CAN DO IT ALL.

... FROM ANY SIDE.

The latest Terex Smart Control (TSC) operating system for precise, comfortable and productive work.

Multi-function joysticks: the 3rd and 4th control circuits are under precise electric proportional control. Various additional functions are integrated directly.

Fingertip control for fast and precise work.

Cab interior with a new performance-enhancing design for a comfortable and productive working environment.

4th control circuit with high flow function (optional) for more hydraulic power: 115 l/min.

Electrics directly and easily accessible in the cab.

2 additional control circuits for operating standard work attachments (optional).

Transversely mounted engine provides easy access for maintenance and acts as a counterweight.

New hood styling with 20% bigger ventilation slots for optimised engine cooling.

Replace tools quickly and easily from the cab using the quick-attach system thanks to two-handed operation.

Automatic self-locking differentials on both axles offer excellent traction.

Articulated steering with oscillating rear axle provides stability, ride comfort, and precise maneuverability, particularly during attachment changes.

Less displacement and fuel consumption, more torque and power with the EU Level IIIB / EPA Tier 4 Final engine.*

* Compared to previous version

POWERFUL ENGINE

**DELIVERS RESULTS IN TERMS OF OPERATION
AND ENVIRONMENTAL PROTECTION.**

FEWER EMISSIONS, MORE POWER

Engine: EU Stage IIIB / Tier 4 Final

Adopting European and American emission levels ensures a significant reduction in particulate emissions compared with previous levels – from 0.4 to 0.025 g/kWh.



TAKE ADVANTAGE OF THE NEW ENGINE TECHNOLOGY:

- ▶ Lower fuel consumption really pays off*
- ▶ The machine is delivered without a diesel particulate filter as standard. This saves on servicing costs. A diesel particulate filter is available on request.
- ▶ Fresh air: pollutants in the emissions from the TL100 are reduced by up to 90%. Significantly fewer particulates are emitted thanks to the advanced exhaust after-treatment. This is achieved by means of improved combustion and injection systems and a diesel oxidation catalyst (DOC)*.
- ▶ Drive characteristics have been optimised for the new engine to deliver performance and meet regulations.

* Compared to previous version



MODERN WORKING ENVIRONMENT

INCREASES PRODUCTIVITY AND SATISFACTION.

THE CAB

Even when it's rough outside, the many features in the cab provide a very pleasant working environment. The control system for the machine uses innovative technology. The machine remains easy to handle, even when used in challenging conditions. This helps driver and machine deliver high productivity.



COMFORTABLE AND FUNCTIONAL

Designed with driver comfort and productivity in mind, the cabs feature noise and vibration damping and are ROPS/FOPS-approved.

SECOND DOOR

- ▶ Optimal cab ventilation
- ▶ Communication possible on both sides
- ▶ Cab easy to clean
- ▶ Improved visibility, even at ground level



DISPLAY AND INSTRUMENTS

A central control unit allows the machinery to be adjusted to the application and the driver. The 3.5" display shows machinery and engine data. The modern menu guide is similar to current smart phones. The windscreen, which domes inwards, minimises the mirror effect.

PRECISE FINGERTIP CONTROL

With the fingertip control, electrical proportional activation of hydraulic functions is simple thanks to a thumbwheel on the joystick. This enables the operator to regulate the oil flow with real precision, all the way from "zero" to "full", which makes it considerably easier to use attachments such as folding buckets, high-tip buckets, or sweepers.



TEREX SMART CONTROL

Terex Smart Control (TSC) is a new Terex operating system for compact wheeled loaders with new engines in the EU Level IIIB / EPA Tier 4 Interim and Final class. It has never been easier to match a Terex construction machine precisely to the driver and application. Numerous controls have also been redesigned and rearranged for quicker operation and improved machine monitoring.

What this means for you:

- ▶ Intuitive operation that is easy to set for each individual driver
- ▶ 3rd and 4th electric proportional hydraulic control circuit for operating work attachments
- ▶ New display design to enable easy machine monitoring
- ▶ Keypad with extra large keys for easy operation

COMPACT WHEELED LOADER TEREX® TL100

EFFICIENT DRIVE

RIGHT ON TRACK.

Responsive, ready for the task at hand, and intuitive: the wheeled loader delivers power exactly where needed – the results are fast work cycles, low fuel consumption, and minimal wear.

ECONOMICAL HYDROSTATIC DRIVE

Operating in a closed circuit, the hydrostatic travel drive delivers lots of power while keeping fuel consumption low. The TL100 loader can achieve up to 20km/h on the road. The optional high-speed version can reach speeds of up to 36 km/h.



ARTICULATED STEERING WITH OSCILLATING REAR AXLE

When used at a densely built-up location or construction sites with limited space, the articulated steering delivers great maneuverability with its 40° steering angle. The articulated steering also allows the bucket to approach the load in a straight line, even at the maximum steering angle. This affords the operator greater flexibility in terms of picking up pallets or setting down loads. The oscillating rear axle has a wide slewing angle of 10°, keeping all 4 wheels in contact with the ground at all times, even when working on uneven ground. The operator also sits parallel to the work attachment at all times. With a Terex wheeled loader, only the rear axle oscillates – unlike other manufacturers, where the whole of the rear end oscillates. This means the weight of the machine is always moving in the same direction as the bucket, which in turn increases the pressure on the ground when backing up.



AUTOMATIC SELF-LOCKING DIFFERENTIALS

All compact Terex wheeled loaders are fitted with permanent all-wheel drive and automatic self-locking differentials on the front and rear axles (35% locking effect). Both provide enhanced traction when traveling in a straight line and turning corners – perfect for bucket loading. The self-locking differentials are activated automatically as required.

ROAD PERMISSION

Terex wheeled loaders may be driven on the road. The TL100 can also be used with an optional towing hitch as a tractor unit.*

BRAKE/INCHING PEDAL

Terex wheeled loaders have a brake/ inching pedal for precise maneuver commands and fast work cycles. This function allows the operator to divert the engine's power from the travel drive to the working hydraulics for fast lifting and setting down of loads.



* May vary according to country standards

POWERFUL WORK EQUIPMENT

SETTING NEW STANDARDS IN REACH AND POWER.

LIFTING FRAME WITH PARALLEL KINEMATICS SYSTEM

Included as standard on all machines, Terex parallel kinematics system allow you to lift a load quickly and precisely without constantly having to adjust the loading angle. While the kinematics system take care of the stroke angle, the operator is free to concentrate on where exactly to set down the load. Terex parallel kinematics system optimise work cycles when loading and unloading the second row on a truck. The clever design ensures the tilt control lever does not collide with the body of the truck.

FORK CARRIER

In tandem with the quick-attach system, the fork carrier offers excellent visibility.

HIGHLY EFFECTIVE HYDRAULICS

The working hydraulics operate completely independently of the hydraulics for the drive.



**COMPACT WHEELED LOADER
TEREX® TL100**

SIMPLE SERVICING

AND QUICK WITH IT.

Simple component layout simplifies service and helps to maximise operating time. Daily tasks can be performed from ground level to save time.



What this means for you:

- ▶ Refueling is quick and time-efficient via the easily accessible service hatch.
- ▶ Large gas-pressured struts make it easy to open the engine hood. The starter, generator, battery, and injection pump are easy to reach, as are the fuel and air filters.

Battery isolator switch

Can be accessed when standing next to the cab.

Jump start terminal

Easy jump starting the machine thanks to free access under the engine hood.

Cab cabling

Simple disconnection of electrical lines when dismantling the cab.



EXCELLENCE AS STANDARD

WITH PERFECTLY TAILORED ADDITIONAL EQUIPMENT.

In order to provide a wheeled loader adapted for the job, Terex offers numerous equipment packages and additional equipment. Using equipment tailored to the job helps increase productivity, reduce wear and damage.

PROTECTION PACKAGE FOR HARSH ENVIRONMENTS

This includes:

- ▶ Special coating with 2K paint
- ▶ Piston rods for lift, tilt, and steering cylinders with chrome/nickel coating (instead of the standard chrome coating)

LIFTING ARM

- ▶ Burst valves for lift and tilt cylinders

HYDRAULICS

- ▶ Fourth hydraulic control circuit
- ▶ Hydraulic shock absorbers
- ▶ Biodegradable hydraulic oil

CAB

- ▶ FOPS modification kit (protection against falling objects)
- ▶ Heated external mirror
- ▶ Supplementary diesel heating (independent of engine) with circulation system
- ▶ Sliding window on right-hand side
- ▶ Air conditioning

MAINTENANCE

- ▶ Central lubrication
- ▶ Electric refueling pump

OPERATION

- ▶ Automatic return to dig position
- ▶ Reverse signal
- ▶ Electronic immobiliser
- ▶ Creeper gear



DIMENSIONS

GENERAL-PURPOSE BUCKET

Capacity (ISO 7546): 1.00 m³
Max. density of material: 1.8 t/m³

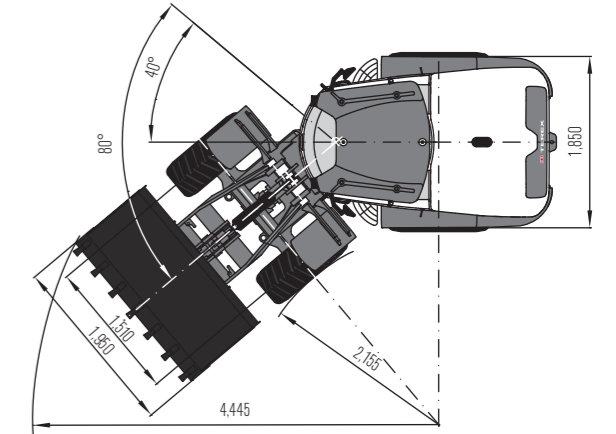
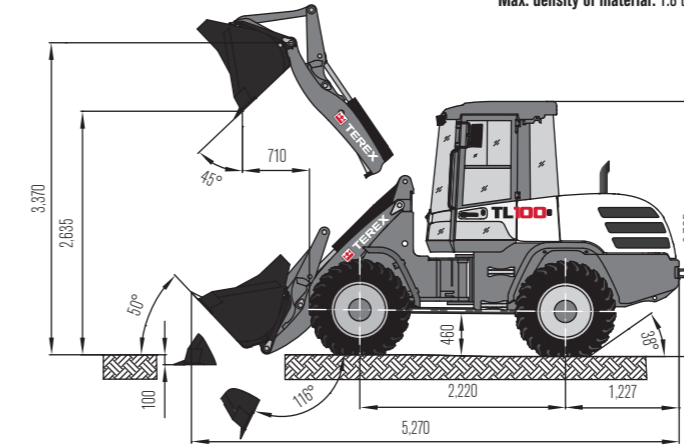

FORK LIFT ATTACHMENT

Operating load over total lift range: 2,400 (2,550)* kg
Operating load in transport position: 3,100* kg
*With rear axle weights

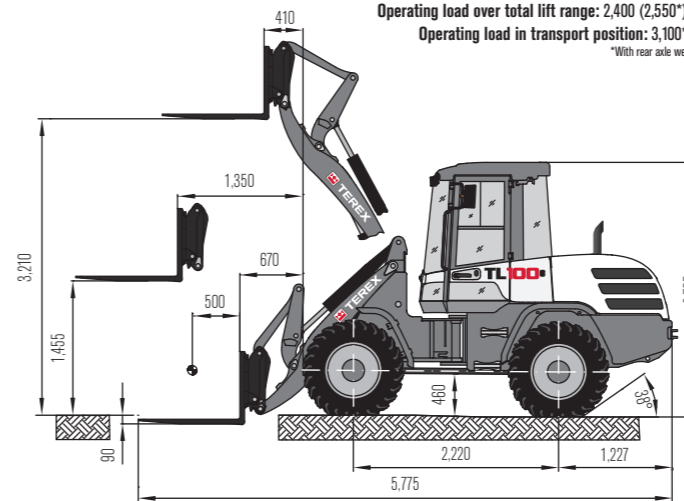

MULTI-PURPOSE BUCKET

Capacity (ISO 7546): 0.90 m³
Max. density of material: 1.6 t/m³

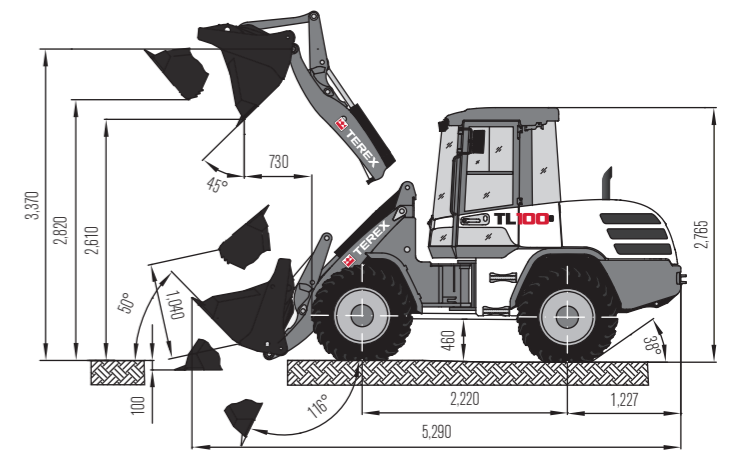

BUCKET TYPE

	Contents	Density	Width	Dump height
General-purpose bucket, quick-attach system (QAS), teeth	1.00 m ³	1.8 t/m ³	1,950 mm	2,635 mm
General-purpose bucket, QAS, bolt-on cutting edge	1.00 m ³	1.8 t/m ³	1,950 mm	2,595 mm
Earth bucket, QAS, teeth	1.10 m ³	1.6 t/m ³	1,950 mm	2,585 mm
Earth bucket, QAS, bolt-on cutting edge	1.10 m ³	1.6 t/m ³	1,950 mm	2,545 mm
Light-material bucket, bolt-on cutting edge	1.35 m ³	1.2 t/m ³	1,950 mm	2,510 mm
Light-material bucket, bolt-on cutting edge	1.55 m ³	0.8 t/m ³	2,100 mm	2,485 mm
Multi-purpose bucket, QAS	0.90 m ³	1.6 t/m ³	1,950 mm	2,610 mm
Side-dump bucket, QAS, without teeth	0.85 m ³	1.8 t/m ³	2,050 mm	2,515 mm
High-tip bucket, QAS, without teeth	1.00 m ³	1.2 t/m ³	2,050 mm	3,835 mm
Quarry bucket, QAS	0.90 m ³	1.8 t/m ³	2,050 mm	2,610 mm
Compost bucket	1.05 m ³	1.2 t/m ³	2,050 mm	2,625 mm

EXAMPLES OF MATERIAL DENSITIES

Granite, basalt, sand (damp), gravel (damp), slate:	1.8 - 2.2 t/m ³	Topsoil, clay, mineral coal:	1.1 - 1.6 t/m ³
Sandstone, gypsum, limestone, soil (damp), sand (dry), gravel (dry):	1.5 - 1.8 t/m ³	Wood chips (dry), compost, coke:	0.2 - 1.0 t/m ³

SPECIFICATIONS

ENGINE

Manufacturer, model	Deutz, TCD 2.9 L4
Type	Turbo diesel engine with intercooler, exhaust-gas optimised EU Stage III B, EPA TIER IV final
Combustion	4-stroke cycle, Common Rail injection
Number of cylinders	4 in line
Displacement	2,900 cm ³
Net power rating at 2,200 rpm (ISO 14396)	55.4 kW (75 hp)
Max. torque	300 Nm @ 1,600 rpm
Cooling system	Water

ELECTRICAL SYSTEM

Nominal voltage	12 V
Battery	12 V / 77 Ah / 760 A (DIN-EN50342)
Generator	14 V / 95 A
Starter	12 V / 2.6 kW (3.5 hp)
Cold-starting aid	Glow plugs 12 V

Lighting system in compliance with StVZO and European standards, halogen H7 headlamps, 2 working floodlights front

POWER TRANSMISSION

Hydrostatic drive, closed circuit, independent from loader hydraulics. Perfected driving automatics, automatic optimisation and adjustment of drawbar pull and speed. Hydraulic motor power shift providing two speed ranges. Infinitely variable speed control forward and reverse. 4-wheel drive from reduction gear on rear axle via cardan shaft to front axle. Inch-brake-drive pedal for sensitive driving and stopping at high rpm.

2 speed ranges:	
“Low”	0-6 kph
“High”	0-20 kph
4 speed ranges (high-speed version optional):	
“Low”	0-5 / 0-12 kph
“High”	0-16 / 0-36 kph

AXLES

Front: Rigid planetary final drive axle, centre-mounted disc brake. Limited slip-type differential 35%.	
Rear: Oscillating (with cushioning) planetary final drive axle, with integrated reduction gear. Limited slip-type differential 35%.	
Angle of oscillation	±10°

BRAKES

Service brake:	Hydraulically actuated centre-mounted disc brake, acting on all 4 wheels via 4-wheel drive.
Auxiliary brake:	Hydrostatic through closed-circuit travel drive.
Parking brake:	Mechanically actuated centre-mounted disc brake on front axle.

TYRES

Standard	405/70 R 20 SPT9 Dunlop
----------	-------------------------

STEERING

Articulated steering, fully hydraulic, 2 steering cylinders with final positioning damping on both sides, oil supply via Load-Sensing priority valve, quick and easy steering even at engine idle-running speed.	
Total steering angle	80°

FLUID CAPACITIES

Fuel tank	110 l
Hydraulic system (incl. tank)	88 l

NOISE LEVEL

Sound pressure level (L _{pa}) in cab	76 dB(A)
Sound power level (L _{wa}) around the machine according to 2000/14/EC	101 dB(A)

Product specifications and prices are subject to change without notice. The photos and/or drawings contained in this document are for illustration purposes only. The relevant operating instructions must be consulted for proper use of our machinery. Failure to follow the relevant operating instructions when using our products or other deviations from the proper operation of the machinery could lead to serious or lethal injuries. The only warranty applicable to our products is the standard written warranty applicable to the particular product. Terex makes no other warranty, express or implied.

OPERATING DATA, STANDARD EQUIPMENT

Operating weight (ISO 6016)	5,800 kg
Tipping load, straight (ISO 14397-1)	4,370 kg
Tipping load, articulated (ISO 14397-1)	3,860 kg
Total length, bucket on ground	5,270 mm
Total width	1,950 mm
Turning radius at outside bucket edge	4,445 mm
Wheelbase	2,220 mm
Total height (top of cab)	2,765 mm

HYDRAULIC SYSTEM

Pump capacity	76 l/min
Working pressure	250 bar

Control unit: Proportional hydraulic valve with 3 control circuits, supplying work functions “Lift / Lower”, “Dump / Tilt-back with high-speed control” and “3rd control circuit (1st additional control circuit)”. Simultaneous, independent control of all movements.

Hydraulic cylinders: 1 lifting cylinder, 1 tilt cylinder, all dual-action

The thermostatically controlled oil circuit ensures that the oil temperature is promptly reached and avoids overheating. Return filter installed in hydraulic tank allows for eco-friendly replacement of filter elements.

Terex 'Fingertip' control for 3rd control circuit, electro-proportional, oil flow limitation via machine function display, continuous operation. Installation on loader frame incl. couplings.

Hydraulically switchable float position by overriding the pressure point “Lower” on the joystick, electrically switchable continuous operation function.

Single, four-way control lever (joystick) with integrated direction-of-travel switch and switch for additional control circuit.

LOADER FRAME

Loader installation featuring true parallel linkage and integrated mechanical (optionally hydraulic) quick-attach system.

General-purpose bucket (ISO 7546)	1.00 m ³
Lift capacity at ground level (ISO 14397-2)	61,000 N
Breakout force at bucket edge (ISO 14397-2)	55,000 N

FORK LIFT ATTACHMENT

Operating load over the total lift and steering range	2,400 (2,550*) kg
Operating load in transport position, approx. 300 mm above ground level, total steering range	3,100* kg
Width of fork carrier	1,240 mm
Length pallet forks (140 x 50 mm)	1,100 mm
Stability factor	1.25

Operating load determined acc. to ISO 14397-2 and EN ISO 474-3 on level ground = 80 % of tipping load.

CAB

Rubber-mounted full-vision steel cab, ROPS (EN ISO 3471) and FOPS** (EN ISO 3449) certified.

Cab featuring two doors, electric windscreen intermittent wipers and washer (front and rear), tinted panoramic safety glass, sliding window on left-hand side.

Driver's seat MSG85 (standard version) with hydraulic cushioning, weight-adjustable, longitudinal and height adjustment and lap belt in compliance with ISO 7096 and ISO 6683.

Cab heating by engine coolant heat exchanger with 3-speed heater fan (choice fresh air/recirculating air) and windscreen defroster, front and rear.

Steering wheel with height and tilt adjustment.

Air conditioning and radio pre-installation.

*With rear axle weights

**FOPS-approved only with skylight guard (optional)



OPTIONAL EQUIPMENT

TYRES

405/70 R 20 EM 01 Mitas
360/80 R 20 TRI2 Nokian
380/75 R 20 XMCL Michelin
400/70 R 20 XMCL Michelin
405/70 R 20 MPT E-70 Continental
405/70 R 20 XZSL Michelin
500/45-20 J331 Alliance (wide tyres)
Non-standard tyres available on request

FRONT ATTACHMENTS

General-purpose bucket*	1.00 m ³
Earth bucket*	1.10 m ³
Light-material bucket*	1.35 m ³
Light-material bucket*	1.55 m ³
Side-dump bucket*	0.85 m ³
High-tip bucket*	1.00 m ³
Multi-purpose bucket*	0.90 m ³
Quarry bucket	0.90 m ³
Compost bucket	1.05 m ³

Front ripper with 4 prongs	
Fork lift attachment: Fork carrier, 1,240 mm wide	
Forks, 1,100 mm, 140 x 50 mm	Forks, 1,200 mm, 140 x 50 mm
Forks, 1,100 mm long, 130 x 60 mm, foldable (StVZO approval possible)	
Load hook, attachable on fork arms	Load hook, integrated in quick-attach system
Broom bucket	Snow blade

*optionally with bolt-on cutting edge

DRIVER'S STAND

Operator's seat MSG 85 (comfort version), hydraulic damping, extra-high backrest, weight-adjustable, lap belt

Air-cushioned operator's seat MSG 95 (premium version) with orthopedic lumbar support, extra-high backrest, adjustable armrests, headrest, seat and backrest heating

Engine-independent diesel heater with timer	Fire extinguisher
---	-------------------

DIESEL ENGINE

Diesel engine with diesel particulate filter (DPF)	Guard for fan wheel
--	---------------------

HYDRAULIC SYSTEM

4 th control circuit, Terex 'Fingertip' control, (electro-proportional control) and installation on lift frame incl. couplings and continuous operation e.g. for attachments with 2 hydr. functions	4 th control circuit, High-Flow, 115 l/min, 180 bar, (electro-proportional control) and installation on lift frame incl. couplings
--	---

4 th control circuit, single-acting, Terex 'Fingertip' control, (electro-proportional control) with pressureless return and installation at rear-end	Hydraulic outlet for front hand-held hammer, with flow divider
---	--

Open return, on lift frame	Bypass filter Kleenoil
----------------------------	------------------------

QUICK-ATTACH SYSTEMS

Quick-attach system, hydraulic	Quick-attach system, hydraulic (Atlas)
--------------------------------	--

Hydraulic installation for hydraulic quick-attach system

CAB

FOPS-skylight guard	Yellow beacon
Right-hand door with sliding window	Radio installation kit
Working floodlight, rear	Air-conditioning

OTHER OPTIONAL EQUIPMENT

High-speed version 36 kph	Anti-theft device (immobiliser)
Filling with biodegradable hydraulic oil, ester-based, BIO-E-HYD-HEES	Special creep versions available on request
Electrical tank refilling pump	Rear axle weights, approx. 260 kg
Pilot-controlled hose-rupture valves for lift and tilt cylinders	Quick couplers (flat face) for 3 rd control circuit on lift frame
Back-up alarm for reverse travel	Ride control system
Central lubrication system	Battery disconnecter
Trailer coupling (Rockinger)	Acceptance as agricultural or forestry tractor
Manual throttle, transmission deactivated	Further optional equipment available on request



**PRELIMINARY
VERSION**

Terex Compact Germany GmbH · Kraftwerkstrasse 4 · 74564 Crailsheim · Germany

www.terex.com/construction

March 2015 · © Terex Corporation 2015 · Terex, the Terex Crown logo and Works For You are trademarks of Terex Corporation or its subsidiaries.



TEREX®

WORKS FOR YOU.™